

Notes on transport, storage and assembly of ROMA quick-assembly insulating panels

| | |
|-------------------------------------|------------------------------------------------------------------------------------------------------------------------------------------------------------------------------------------------------------------------------------------------------------------------------------------------------------------------------------------------------------------------------------------------------------------------------------------------------------------------------------------------------------------------------------------------------------------------------------------------------------------------------------------------------------------------------------------------------------------------------------------------------------------------------------------------------------------------------------------------------------------------------------------------------------------------------------------------|
| Deliveries | <p>The truck driver shares responsibility for proper loading of the truck and for suitable transport.</p> <p>Prior to loading, please check to make sure the elements have arrived undamaged.</p> <p>Check the shipment for completeness and for any transport damage.</p> <p>Immediately report complaints upon receipt and enter the complaints as well as the name of the driver, the truck license plate number and your name in the shipping documents.</p> <p>In the case of transport damage that is not immediately reported, it is assumed that the damage occurred after unloading.</p> |
| Unloading | <p>Externally visible claims that are not noted on the consignment note are not subject to complaint at a later date.</p> <p>When unloading with a crane, always use belts and the supplied unloading planks. Place the planks on the places marked in red! (see back page)</p> <p>Always use traverses if panel lengths are greater than 10 m.</p> <p>Never unload two bundles at the same time.</p> <p>For closed trucks, remove the tarpaulins to unload.</p> <p>If unloading is done with a forklift truck, the truck driver must monitor this carefully. It is the responsibility of the truck driver to hand over shipment without damage.</p> <p>The forks are to be placed in the middle of the packing pallets.</p> <p>Damage occurring during unloading shall be borne by the buyer.</p> |
| Storage | <p>Store the bundles on a flat surface with enough suitable material underneath them. Stack bundles no more than two high.</p> <p>Packages with sandwich panels must be stored at an angle so that any moisture in the package, e.g. rain, condensation, can be removed.</p> <p>A rainproof, well-ventilated cover is required for the packages stored outdoors. Factory-made package wrappings must be opened at the ends to avoid condensation.</p> <p>Sufficient distance to the ground must be provided.</p> <p>Even under optimal storage conditions, a storage period of 6 months must not be exceeded, otherwise the properties of the panels may change.</p> <p>Storage in a permanently humid environment must be avoided.</p> |
| Packaging / Protective foils | <p>Transport aids, foils and protective wrappings of construction elements as well as residual and cut waste shall become the property of the Contractor and shall be recycled or disposed of by the Contractor as an ancillary service within the regulations of the VOB/C and in compliance with the Closed Substance Cycle Waste Management Act and the Trade Waste Ordinance. The vendor shall not be obliged to collect transport packaging.</p> <p>Completely remove the protective foils immediately after assembly, on the same day at the latest. The same applies to the protective film on the back of the sheet metal for roof panel overlaps (cross joints).</p> <p>Protective foil on the roof and wall elements are only designed for short-term storage. The adhesion of the protective foils on the panel surfaces constantly increases. Therefore, take special care to safeguard the protective foil from sun exposure.</p> |
| Assembly | <p>The relevant regulations for assembly of sandwich panel elements (issued by IFBS Düsseldorf) must be observed during assembly. The same applies to the protective film on the rear of the sheet metal on roof panel end laps.</p> <p>The accident prevention regulations and safety regulations for assembly of roof and wall sandwich panel elements must be observed.</p> <p>Only use cutting tools which work without flying sparks and substantial heat build-up.</p> <p>Immediately remove metal burrs, rivets and other foreign objects.</p> <p>Be careful about sharp edges and hazardous edges which cannot be avoided on the panels.</p> |

No warranty is extended for any damage resulting from failure to observe these notes!

In the case of crane unloading, please note:

Up to 10 m max. in length:

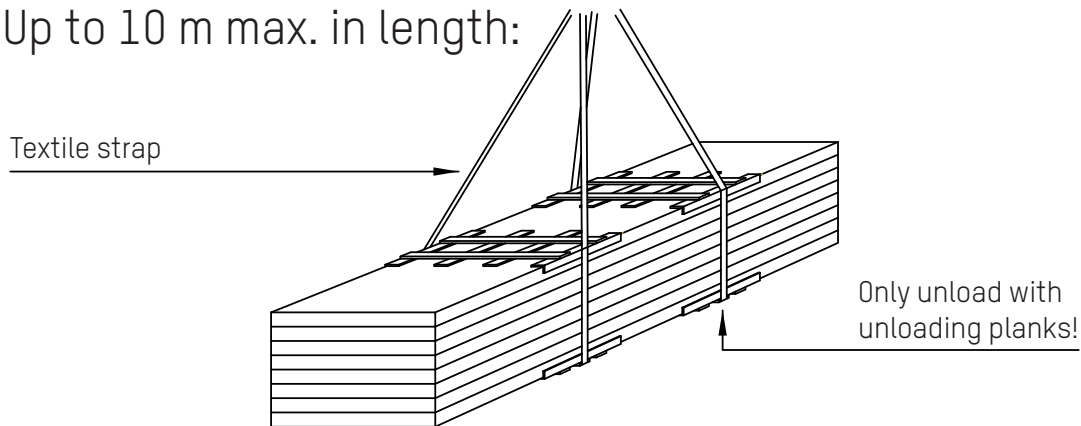

More than 10 m in length:

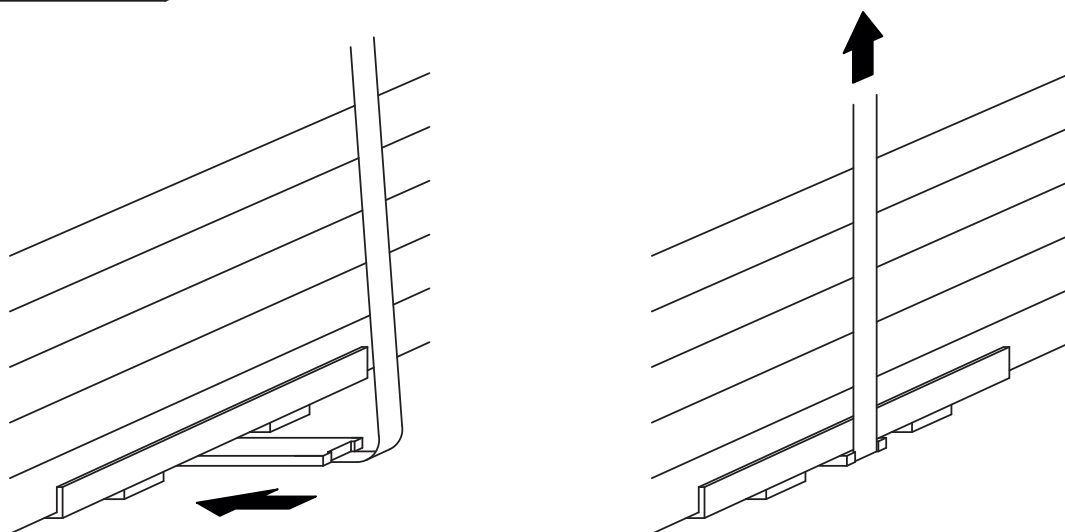
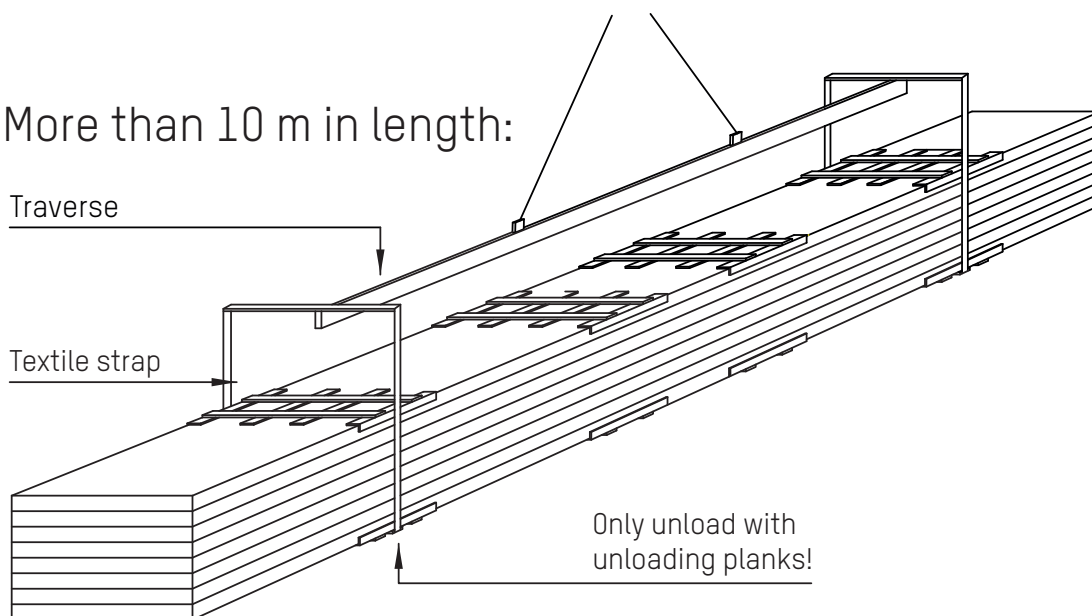

Please place loosely supplied unloading planks at the points marked in red!