

MW-wall-panel-fire protection, soundproofing and thermal insulation

Base

F 401-1

As of: 03/22

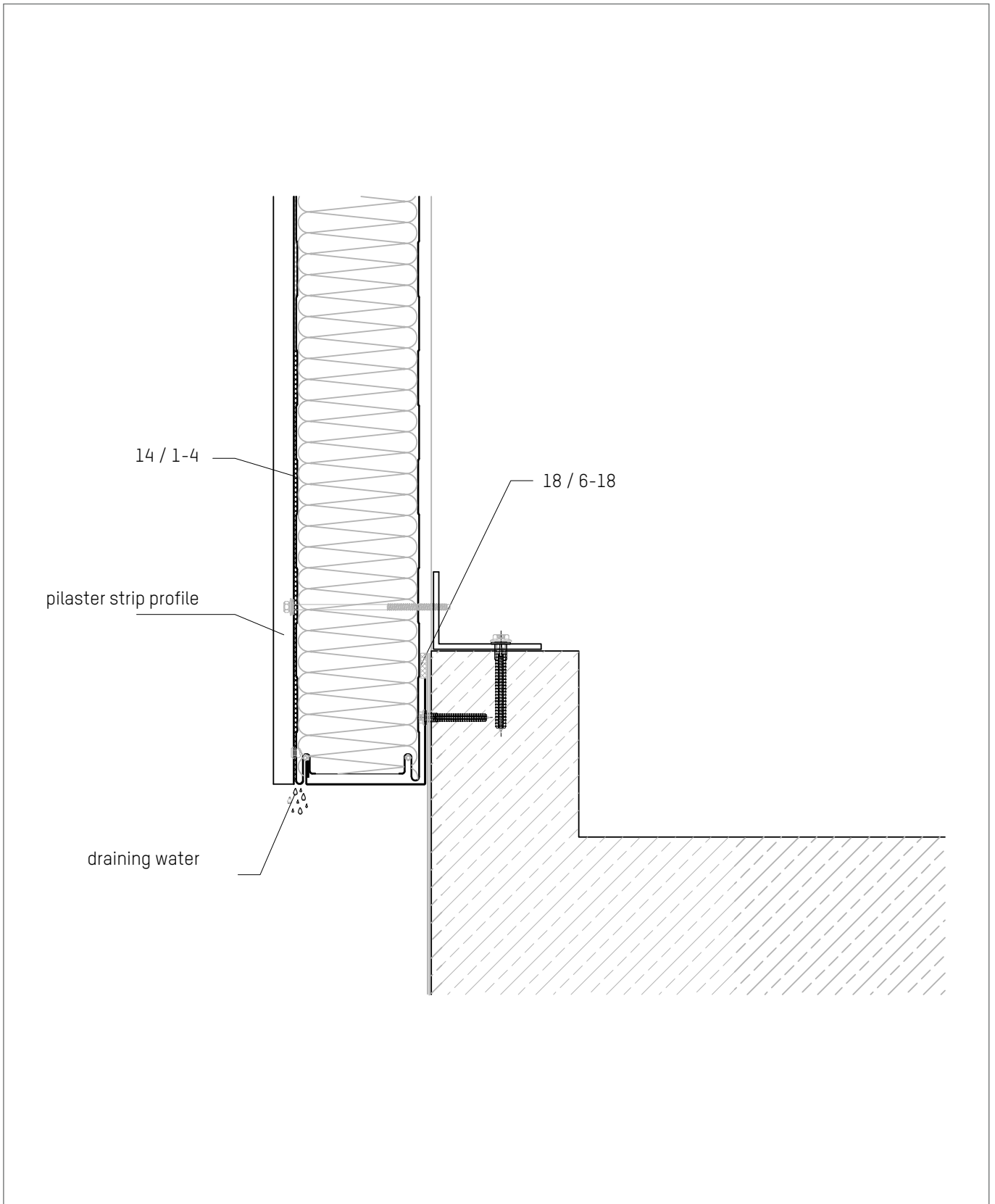

MW-wall-panel-fire protection, soundproofing and thermal insulation

Base

- laid horizontally -

F 402-1

As of: 03/22

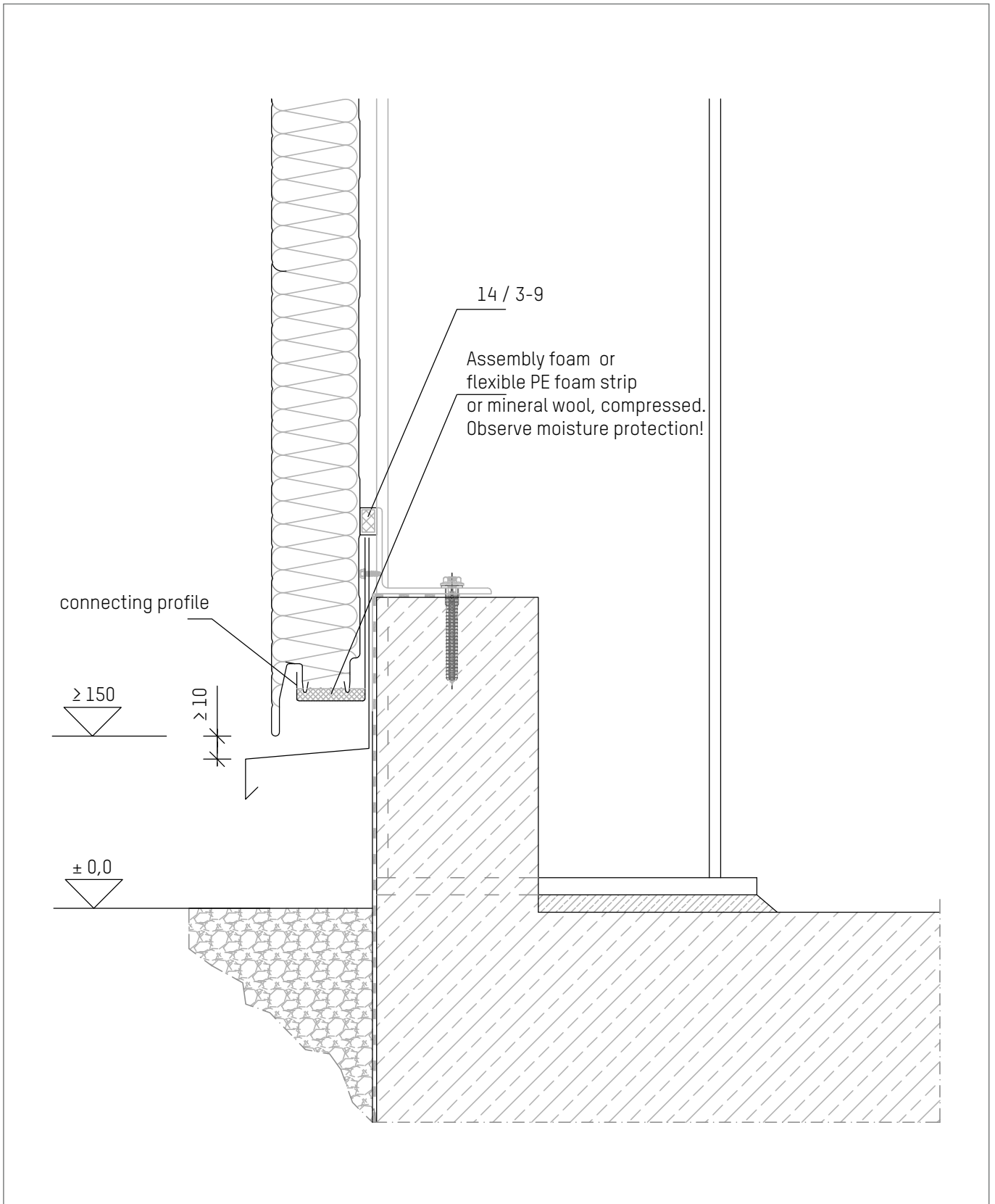

MW-wall-panel-fire protection, soundproofing and thermal insulation

Base

- laid horizontally -

F 403-1

As of: 03/22

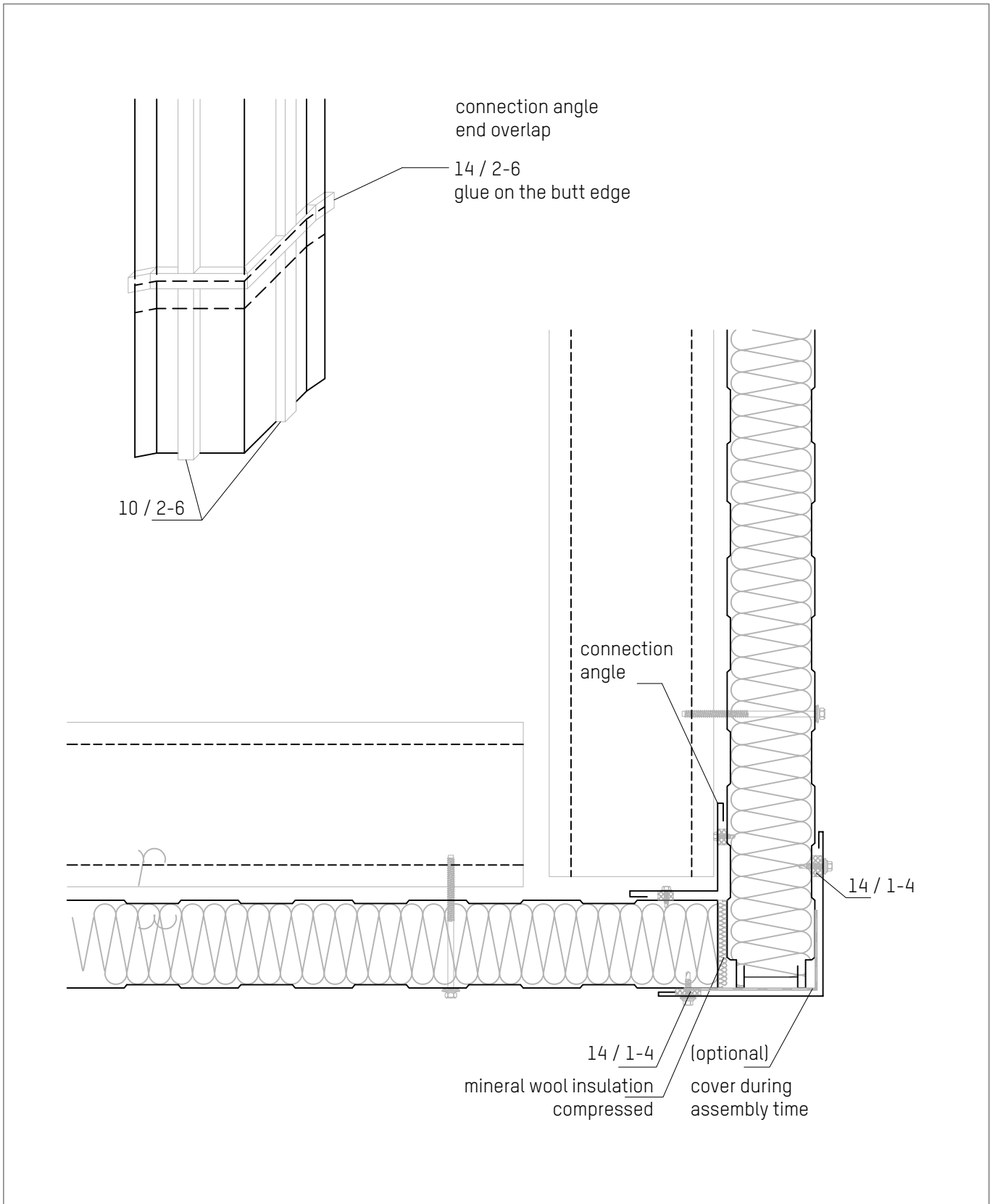

MW-wall-panel-fire protection, soundproofing and thermal insulation

Outside corner

F 404-1

As of: 03/22

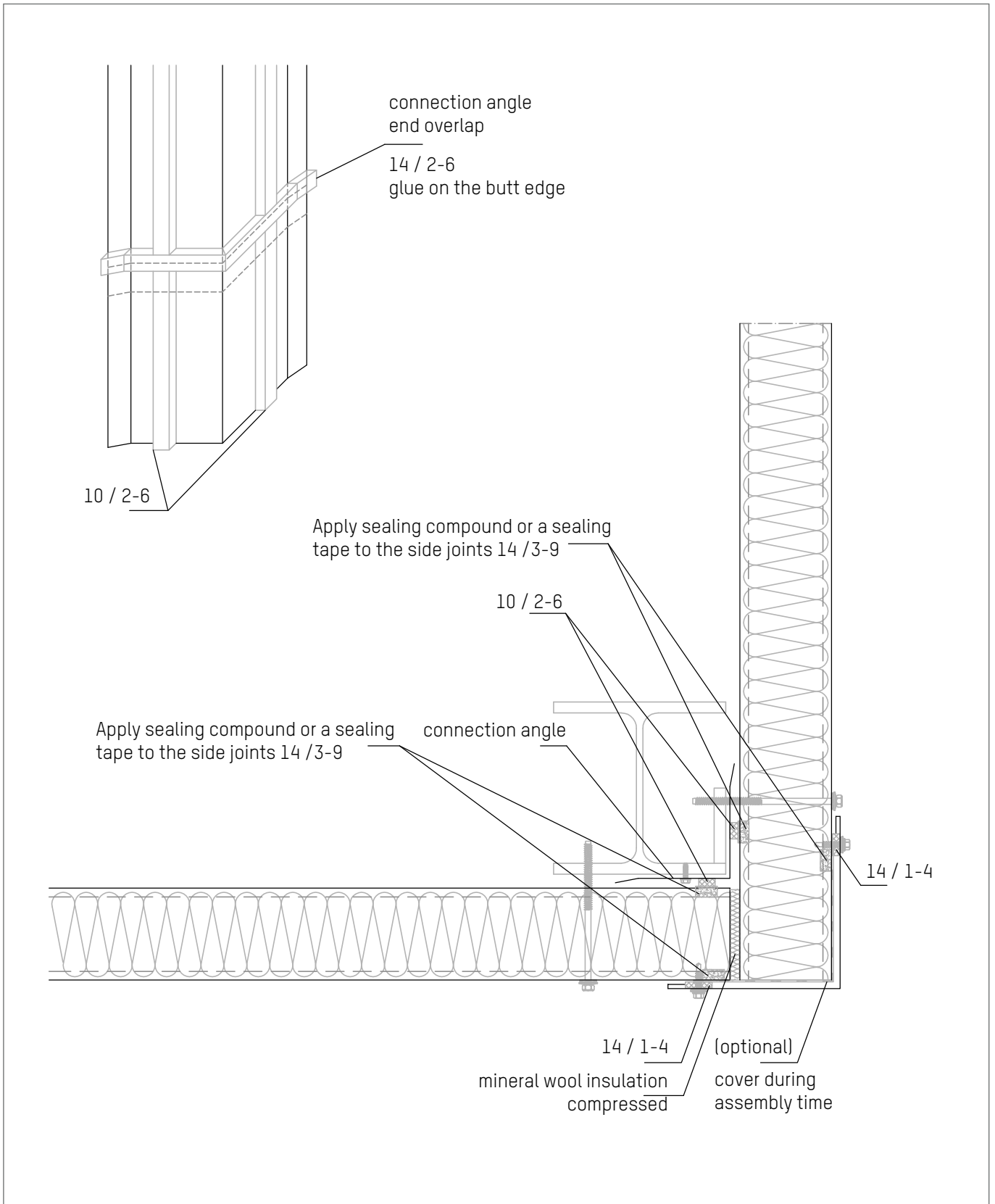

MW-wall-panel-fire protection, soundproofing and thermal insulation

Outside corner

- horizontal -

F 405-1

As of: 03/22

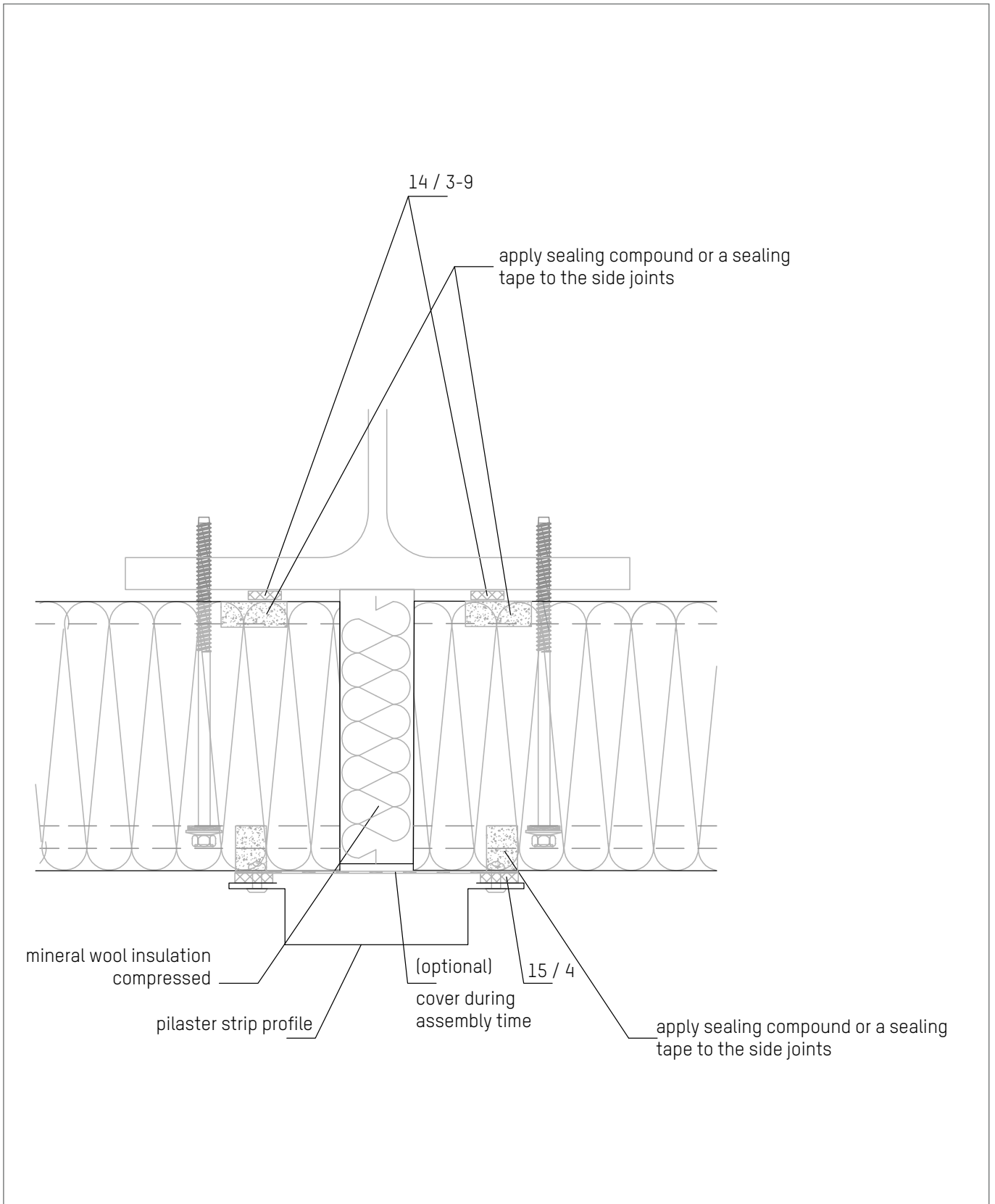

MW-wall-panel-fire protection, soundproofing and thermal insulation

End lap with pilaster

- horizontal -

F 406-1

As of: 03/22